

BP-F112 (BATTERY OPERATED) WALL MOUNTED SENSOR FAUCET CHROME-PLATED BRASS METAL BODY



Rotatory Swan Neck Design With Linear Sensor For Seamless User Experience



- Input : 6V DC
Thru 4 X AA size Alkaline Batteries
- Sensing range adjustable
(150mm)
- Safety shut off
(False sensing automatic cut off
after 1 minute)
- Working water pressure
(0.2 Mpa-0.8Mpa)
- Intelligent touchfree
Infra-red sensor
- 15mm through control box with
inbuilt solenoid valve

DIMENSION

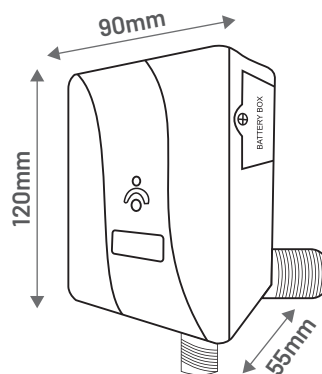
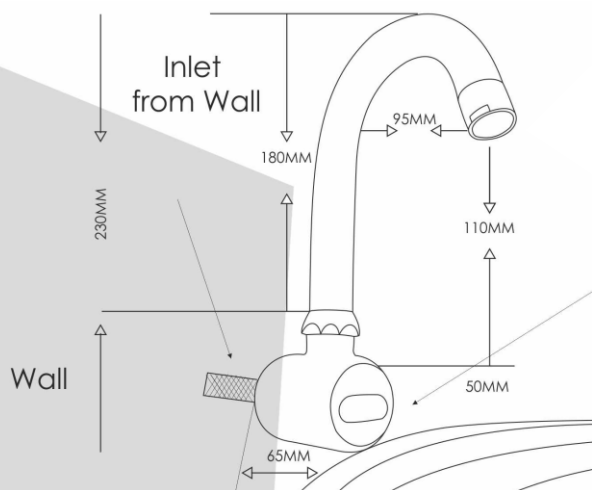

ENHANCED CONTROL UNIT (Waterproof, Easy to serviceable)

EASY INSTALLATION WITH
BACK MOUNTING CLAMP.
REQUIRED ONLY 2 NOS SCREW
FOR INSTALLATION

BATTERIES CAN BE REPLACED
WITHOUT OPEN THE CONTROL UNIT



scan for website

BPE INNOVATIONS PVT. LTD.

ADD : A-23/19, Site-IV, Sahibabad
Industrial Area, Ghaziabad (UP) 201010

Web : www.bharatphoton.com
E-mail : enq@bharatphoton.com

TOLL FREE : 1800 121 6254