

## OPERATION AND WORKING :-

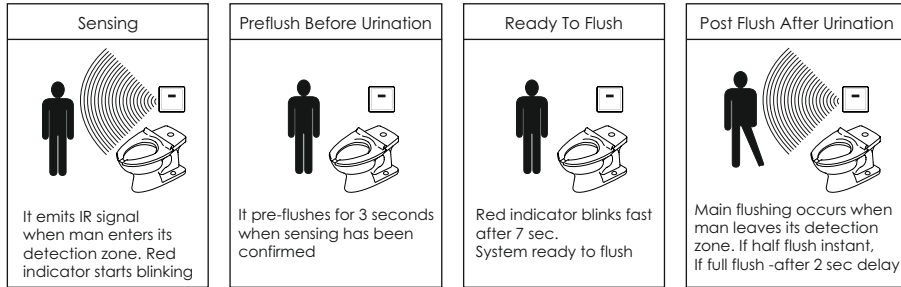

### SPECIAL WATER SAVING DUAL FLUSH MODES

**Half flush for urinal application :** Its smart brain will calculate urine application if person removes before 90 sec of continuous sensing & provide half flush of 3 sec to save water.

**Full flush for stool application :** Its smart brain will calculate stool application if person removes after 90 sec of continuous sensing & provide full flush of 8 sec as per the preset setting after ON delay of 2 sec when person removes.

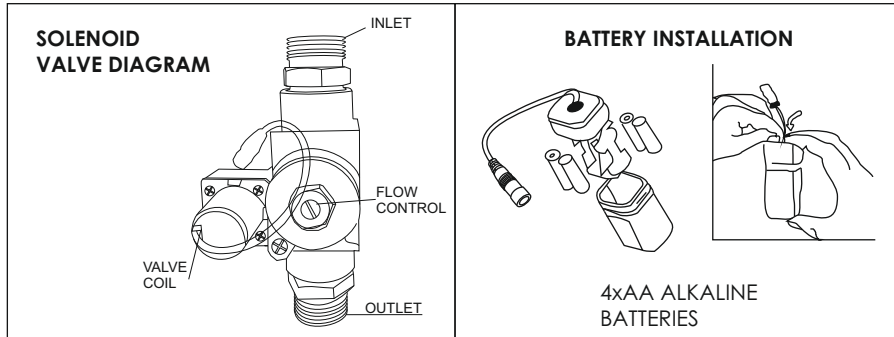

### PRECAUTION :-



### CUSTOMER SUPPORT :-

#### AFTER-SALES SERVICE

Our Customer Support Team is comprehensively trained to provide help and advice, spare parts or a service visit.

#### SPARE PARTS

We maintain an extensive stock of spares and aim to have functional parts available for ten years from the date of final manufacture of the product. Spares can be purchased from approved stockists or merchants (locations on request) or direct from our Customer Support Department. Spares direct will normally be dispatched within two working days.

#### NOTE

In the interest of safety, spares requiring exposure to mains voltages can only be sent to qualified persons.

#### SERVICE

Our Customer Support Team is available to provide quality service at a reasonable cost. You will be assured of the services of a trained engineer I agent, genuine spares and a 3-month warranty on the repair.

**Bharat Photon®**  
bringing India to the world...

## AUTOMATIC TOILET FLUSER



## INSTALLATION & OPERATION MANUAL

1. Designed and manufactured in India to automatically flush toilet pot after every use.
2. An essential & dependable component in every washroom to maintain proper hygiene.
3. Simultaneously instrumental to help reduce water wastage.
4. Intelligent flushing ensures your wash room remains stink free.
5. Recovers its cost by saving significant amount of water as compared to washroom with manual flushing.
6. Tried and tested easily serviceable & lifetime repairable product, very adaptive to robust Indian conditions.
7. Essential for green buildings and must for every public washroom.
8. Reduces carbon footprint & saves considerable amount of operational costs as compared to conventional flushing techniques.
9. Dual Flush Modes to save water

### SPECIFICATIONS :-

Model	BP-W442S	
Power	DC 6V	AC 220V 50Hz / DC 6V - 4XAA Alkaline batteries
Sensing Range	500 mm adjustable through preset	
Water Pressure	0.05Mpa - 0.8 Mpa	
Flush Time	2-3 Seconds preflush and 7-8 seconds postflush adjustable through preset	
Inlet / Outlet	40mm	
Remark	Sensing range (or detection zone) adjustment pot given at sensor ▶ By default range is preset at optimum value ▶ Alter setting only if necessary	

**A PRODUCT PROUDLY DESIGNED & MANUFACTURED IN INDIA**

## INSTALLATION PROCEDURE :-

1. Clean the pipeline by running 1~2 bucket water until dust particles like cement pieces or thread etc. are washed away.
2. Unscrew the front plastic cover and grout the stainless steel box with inbuilt valve inside the wall with bottom at approximately 1000 mm height from the floor.
3. Now install the water pipeline to W.C. pot through the inlet and outlet of S.S. Box.
4. Screw the front plastic cover on the box until the site is prepared for final connection & keep the sensor separately in the packing to ensure the safety of sensor & items inside the wall box.
5. Complete the finishing & do tiling up to the level of front plastic cover.

Now the sensor is ready to install as directed below:-

6. Install 4xAA size Alkaline batteries into battery compartment & connect the battery pack to sensor or ac/dc adaptor as per the stickers on the leads
7. Connect the solenoid valve lead of sensor to solenoid valve
8. Place the battery pack inside the S.S. Box at proper place.
9. Now take out the front magnetic S.S. Sheet of the sensor through the vacuum sucker to reach the four corner screws behind it. Screw the sensor properly to the wall S.S. Box and place back the magnetic sheet on the front.

YOUR BATTERY OPERATED AUTO FLUSH SENSOR FOR W.C. IS READY FOR USE NOW.

## IN-BOX CONTENTS



Sensor Plate

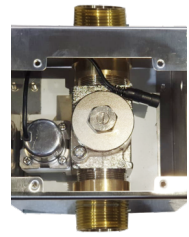

S.S. Wall Mounted Box With inbuilt Solenoid Valve



Battery Pack



AC/ DC Adapter In BP-422E only



Protective Cover with Installation Kit

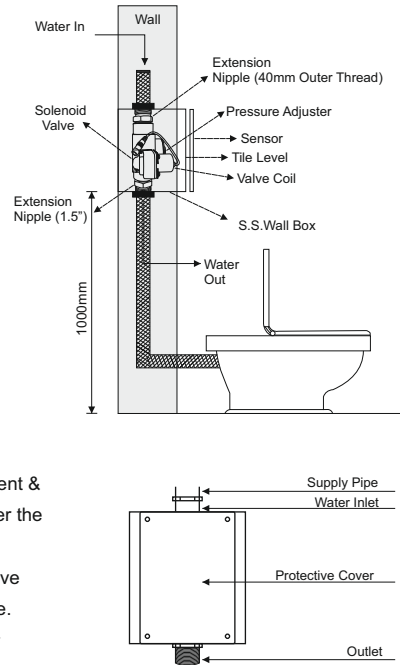

## Automatic W.C. Flusher Troubleshoot Flowchart

