



Troubleshooting.

FAULT	CAUSE	ACTION
No water but indicator light on control box working	<ul style="list-style-type: none"> - Water supply cut off - Dirt in the filter - Water pressure too low 	<ul style="list-style-type: none"> - Check water supply - Check filter (located in water inlet fitting) - Raise pressure
Water will not turn off	<ul style="list-style-type: none"> - Sensor window dirty - If indicator working on sensing - If indicator not working on sensing 	 <ul style="list-style-type: none"> - Clean sensor window - Decrease sensing range from C.U. adjustment pot by rotating it anticlockwise - Clean solenoid valve big dust particle struck in valve
Too little water flow	<ul style="list-style-type: none"> - Water supply restricted - Dirt in the filter - Water pressure too low 	<ul style="list-style-type: none"> - Check water supply - Check filter - Raise pressure
Too much water flow	<ul style="list-style-type: none"> - Water supply turned on too high - Water pressure too high 	<ul style="list-style-type: none"> - Adjust supply - Adjust pressure
Indicator light not working while sensing	<ul style="list-style-type: none"> - PCB or wiring loom wet - Battery loose or AC power not available 	<ul style="list-style-type: none"> - Check Battery/ AC Plug - If not resolved, Contact manufacturer
Sensing distance very less	<ul style="list-style-type: none"> - Range is very low 	 <ul style="list-style-type: none"> - Increase sensing range from C.U. adjustment pot by rotating it clockwise

* While rotating the adjustment pot make sure to NOT apply force on minimum & maximum thresholds as it can free the pot.

CUSTOMER SUPPORT

AFTER-SALES SERVICE

Our Customer Support Team is comprehensively trained to provide help and advice, spare parts or a service visit.

SPARE PARTS

We maintain an extensive stock of spares and aim to have functional parts available for ten years from the date of final manufacture of the product. Spares can be purchased from approved stockists or merchants (locations on request) or direct from our Customer Support Department. Spares direct will normally be dispatched within two working days.

NOTE

In the interest of safety, spares requiring exposure to mains voltages can only be sent to qualified persons.

SERVICE

Our Customer Support Team is available to provide quality service at a reasonable cost. You will be assured of the services of a trained engineer/agent, genuine spares and a 3-month warranty on the repair.

www.bharatphoton.com

Proudly Designed and manufactured in India.

Installation Instructions

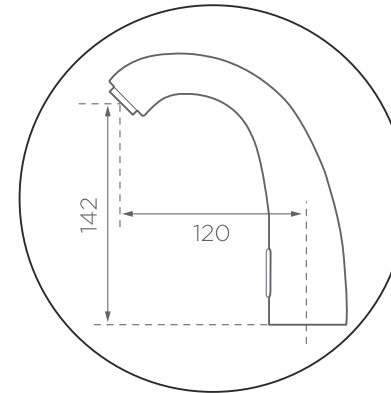

Bharat Photon®
where sensors mean  'India'

**BASIN MOUNTED
ERGONOMICAL
SWAN NECK
DESIGN**

INSTALLATION & OPERATION MANUAL

1. Designed and manufactured in India to automatically wash hands without the need to touch the tap.
2. An essential & dependable component in every washroom to maintain proper hygiene.
3. Simultaneously instrumental to help reduce water wastage.
4. Prevents the spread of germs due to physical contact of tap.
5. Ensures no one leaves the tap running after use as water flows only for the duration when hand is in front of the sensor.
6. A tried and tested easily serviceable & lifetime repairable robust Indian answer to use & throw 'locally branded imported models' marketed widely in India.
7. A true Indian product that confirms to Green Building Standards.
8. Reduces carbon footprint & saves considerable amount of operational costs as compared to manual taps.

SPECIFICATIONS : -

MODEL	BP-F062 - Basin Mounted Sensor Faucet
POWER	6V DC/ 220V AC
SENSING RANGE	150 mm Adjustable
WATER PRESSURE	0.02 MPa - 0.8 MPa *0.05 MPa is minimum required pressure for decent flow of water
INLET	G1/2" (Dn15)
SETTINGS	Sensing range adjustment pot given at control unit <ul style="list-style-type: none"> ● By default range is preset at optimum value ● Alter setting only if necessary

Installation Diagram

Determine Component Location

Determine the location of each of the components, taking into account the tube lengths and space available.

The installation location should be away from sources of bright light and sunshine.

Plan Dispense Position

Determine the position of faucet mounting hole in sink top or benchtop. Hole size required is 25mm.

Advantage

Ergonomical Swan Neck Design with Stylish & Sleek Front Sensor. Solid brass construction.

Finish: Chrome-plated.

Hands free infrared activation.

Turn Off Your Water Supply

Locate your mains water valve and switch it off. Then, run all of the hot and cold taps to drain any water still in the system. This will ensure you don't experience any big spills during installation.

Install Your Sensor Tap

Pass your new sensor tap, its inlet pipe and sensor cable through the mounting hole on your basin, then get down underneath it again. Tighten the faucet body with check nut provided.

Attach the water inlet pipe to the corresponding inlet point on your tap's controller box.

Install reducer with washers (as shown in Image) at the outlet of control box and then install pipe from faucet with washer through it.

Mount Control Box

Easy installation with back mounting clamp. Required only 2 nos screw for installation. Unit can be taken out easily for servicing by Sliding out from back mounting clamp

Note : Warranty void if control box fitted upside down or sideways.

Connect The Sensor Cable/ Power Supply-

Next, attach the sensor cable from your tap to the controller box. Once done, open the top cover on your controller and load it with the appropriate batteries. In this instance, this tap requires 4 x AA batteries.

Plug the power cable into the power supply box

Note : Before starting any electrical work ensure the power supply is isolated.

In-Box Contents

- ▶▶ Sensor Faucet
- ▶▶ Control Unit

Installation Kit

- ▶▶ 2 nos. Fitting Rod
- ▶▶ 2 nos Copper Nut
- ▶▶ 1 no Rubber Mat
- ▶▶ 1 no Stainless Steel Mat
- ▶▶ 4 nos. Screw set

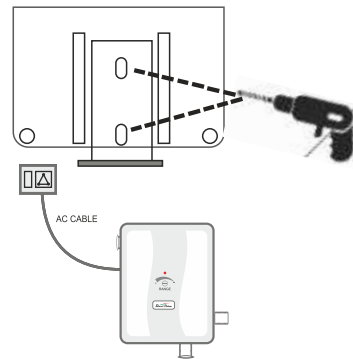
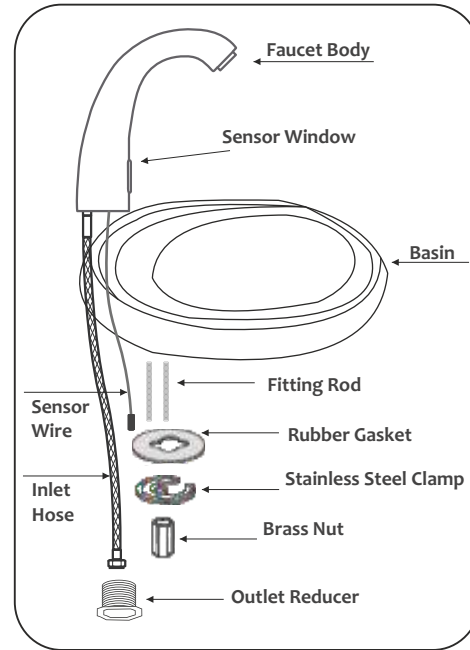

CONNECTION DIAGRAM OF CONTROL UNIT :-

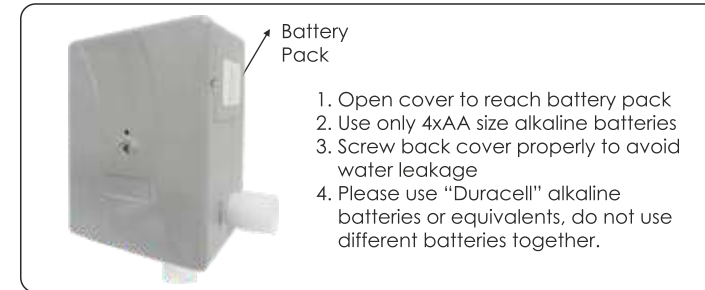

LIGHT NOTIFICATION

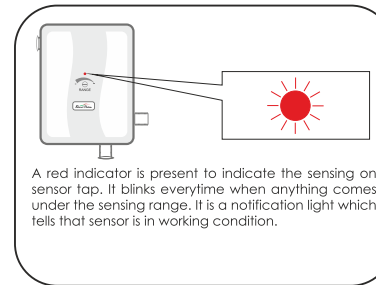

HOW TO CLEAN THE STRAINER

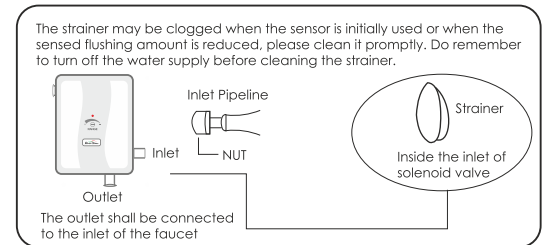

ROUTINE CARE AND MAINTENANCE

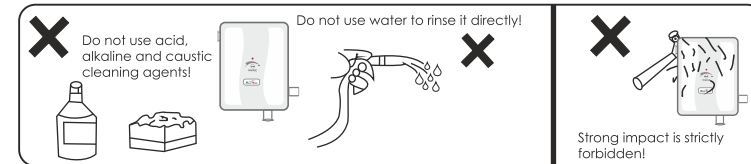

Flexible Connecting Hose

Care must be taken when connecting the flexible connection hose from the power supply box to the spout to ensure it does not bend sharply and kink or twist.

See below for recommended ways to fit the flexible connecting hose.

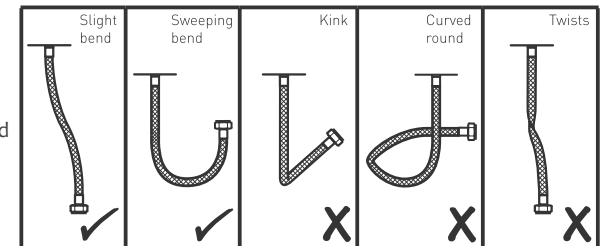

⚠ Important: Failure to follow these guidelines may result in poor performance and damage to the flexible connection hose.